

Instructions 1 – Make a Crumble Robotic Vehicle

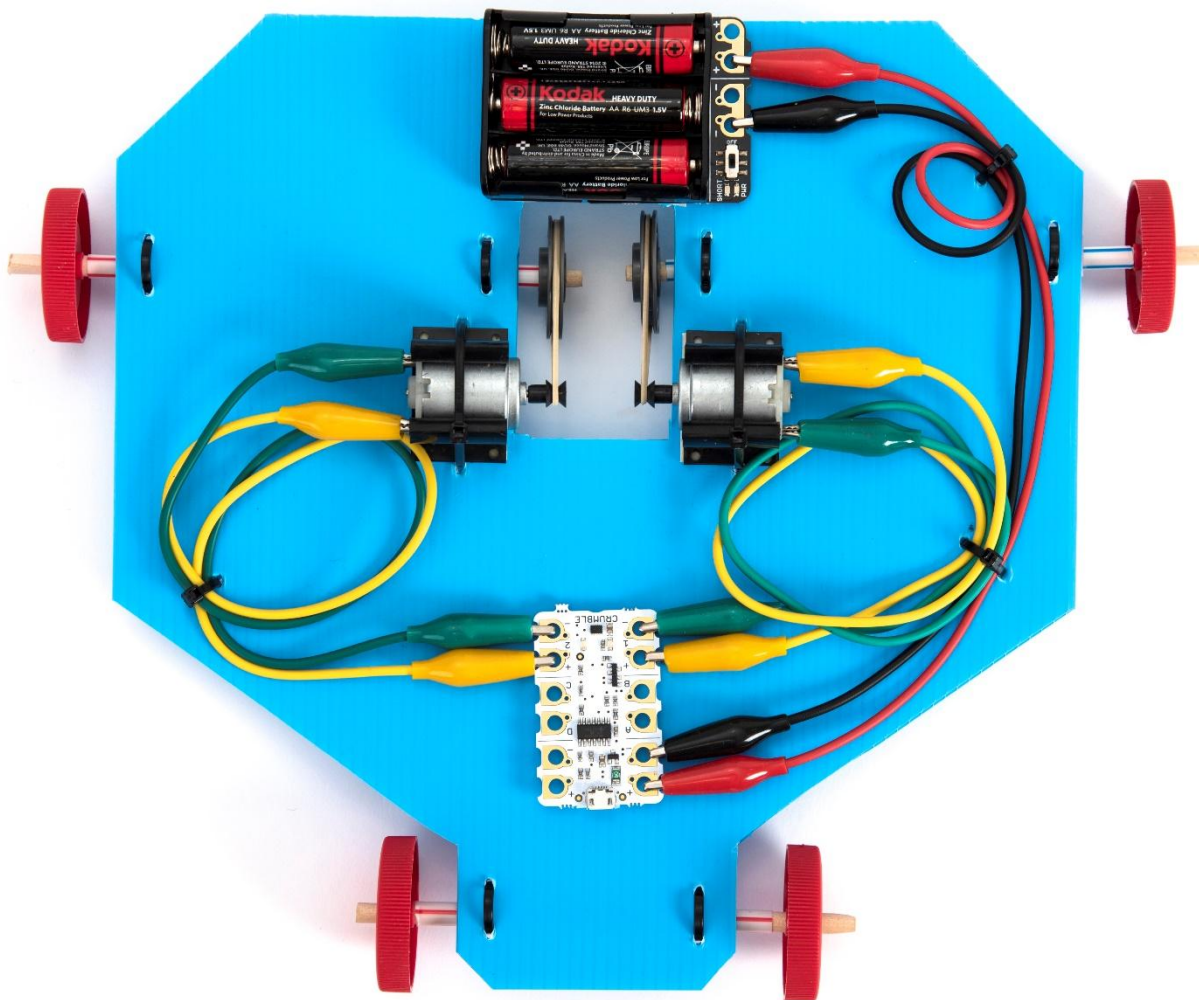

Crumble Vehicle Project

Copyright © Caroline Alliston 2026

Follow this step-by-step guide on how to make and program a Crumble robotic vehicle.

Associated resources:

- Crumble Robotic Vehicle Lesson Plan
- Presentation 1 – Create your Crumble Robotic Vehicle
- Worksheet 1 – Crumble Robotic Vehicle

You will need:

Parts included in class kit:

- 1 square of corrugated plastic 25cm x 25cm
- 1 Crumble controller
- 1 micro-USB cable
- 6 crocodile leads
- 1 switched battery box 3xAA
- 2 pulleys 30mm diameter
- 2 rubber bands 6cm long x 1.5mm wide
- 4 wheels
- 2 motors
- 2 motor mounts
- 2 motor pulleys
- 11 cable ties
- 3 jumbo paper drinking straws
- 1 wooden rod

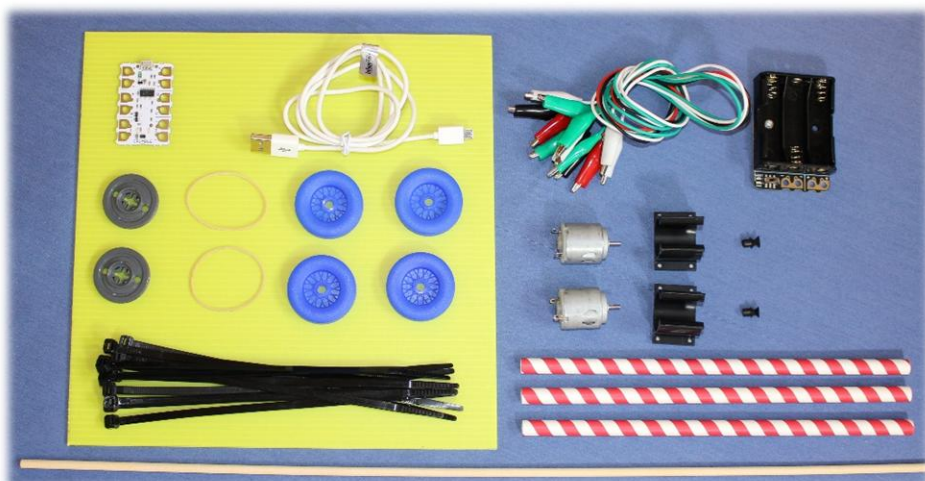

Note: You can measure the length of a rubber band by laying it flat alongside a ruler (without stretching it) as shown here.

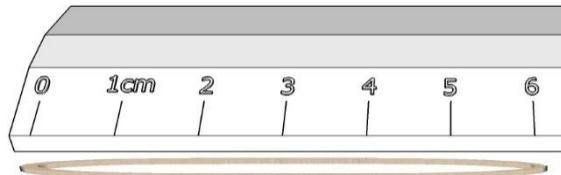

Other parts, tools and consumables

- 1 computer with internet connection (Netbook computers will work, but not Chromebooks)
- Ruler
- Fine marker pen
- Pencil sharpener
- Sandpaper
- Blu Tack
- Sharp pencil
- Double sided foam sticky tape, 12mm wide x 1mm thick, heavy duty
- Large scissors
- 3 AA cells
- Cutting mat
- Craft knife
- Straight edge
- Secateurs

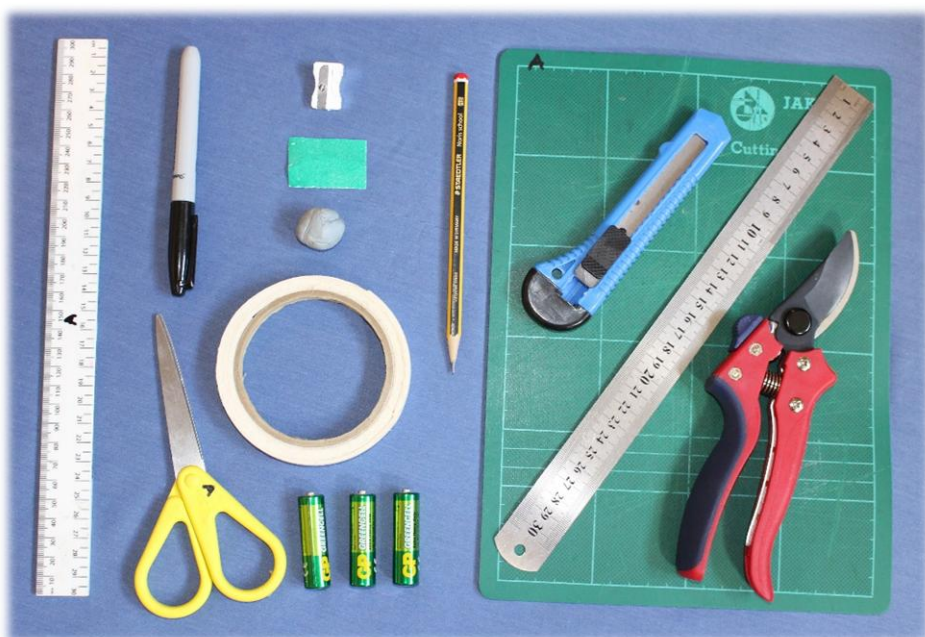

Step 1

Use the ruler and marker pen to mark out the shape shown here on the corrugated plastic sheet. Make sure the sheet is orientated so that the corrugations run in the direction shown by the blue arrow. This is to help maximise the stiffness where the base is most vulnerable (4cm from the front). Cut out using the craft knife, straight edge and cutting mat. This is your base.

(To make it easier to do the rectangular cut-out, you could make a hole in each corner with the sharp pencil. Support the base on a lump of Blu Tack just under where you are making the hole, to avoid damaging the base, the table or your fingers. Cut from hole to hole with the craft knife.)

Before you assemble your vehicle, you may wish to use your base as a template to draw round to make the bases for the class (see the Crumble Robotic Vehicle Lesson Plan).

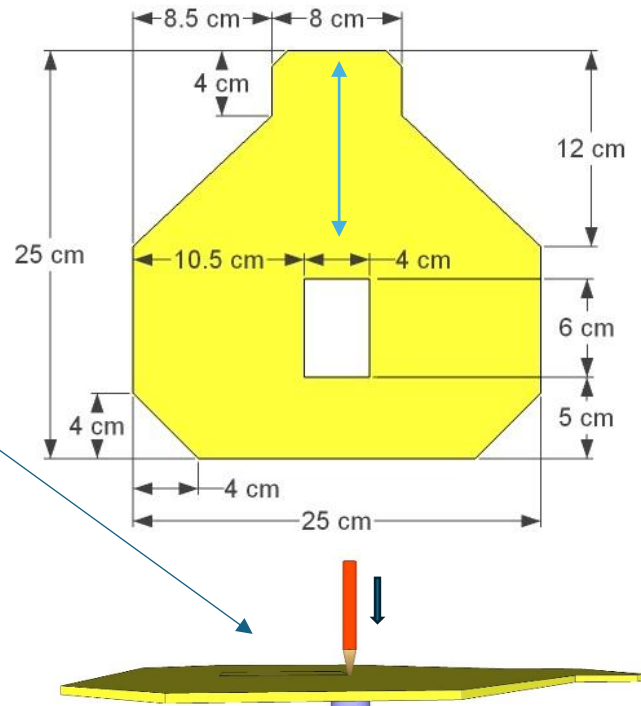

Step 2

Use the ruler and marker pen to mark the lines shown here on the base. These are to help you position the components correctly. The left-hand diagram shows the underside and the right-hand diagram shows the top.

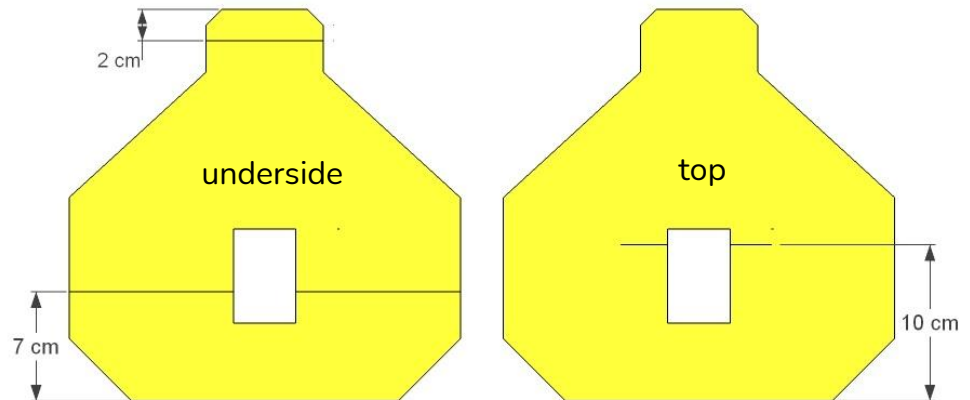

Step 3

Stick an 8cm long strip of double-sided foam tape centrally along the line you marked 2cm from the front of the underside of the base. Use the sharp pencil to make holes in the base immediately either side of the foam tape, roughly 1.5cm in from the edge. The holes need to be in between the corrugation lines. Support the base on a lump of Blu Tack just under where you are making the hole, so you don't bend the base or pierce your fingers. Use the pencil to enlarge the hole from both sides until a cable tie fits through.

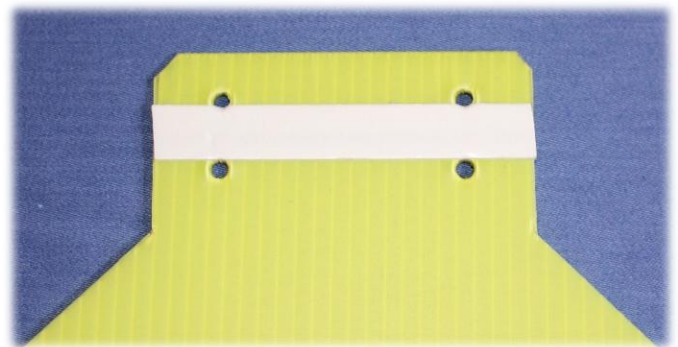

Step 4

Measure, mark and cut a piece of straw 9.5cm long. The cut end will become flattened – round it out again with the pencil. Peel the protective film off the foam tape. Stick the piece of straw to the foam tape, with roughly equal overlap on either side. This is the front bearing.

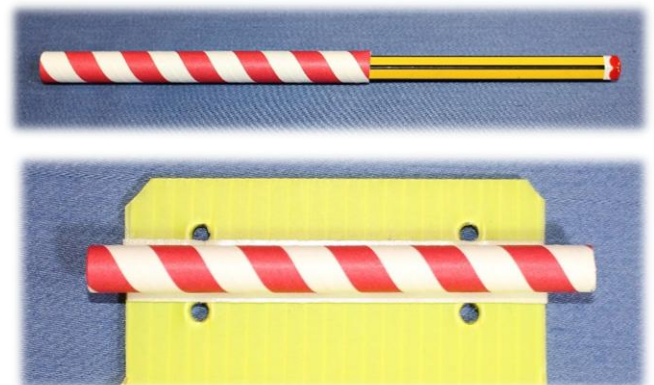

Step 5

Use the secateurs to cut a piece of wooden rod 14cm long. Sharpen the ends slightly (see picture) with the pencil sharpener to help the wheels go on. This is the front axle.



Step 6

Fit one plastic wheel to the end of the axle. Push a second wheel onto the other end to make sure it goes on easily, then take it off again. Slide the axle through the bearing and refit the second wheel. Make sure there is a small gap (about 2 mm) between the wheel and the end of the straw bearing. You can adjust the gap by holding both wheels and twisting them in opposite directions. Hold the base in your hand off the table and spin a wheel with your finger to make sure the axle rotates freely in the bearing.

N.B. The wheels should be a tight fit on the axle. However, the wooden rod (axle) can vary slightly in diameter. If the wheels are too tight to fit you can sand the axle down a little. If the wheels are loose, glue them onto the axle. Be careful not to glue the wheel to the bearing, as this will stop it from turning.

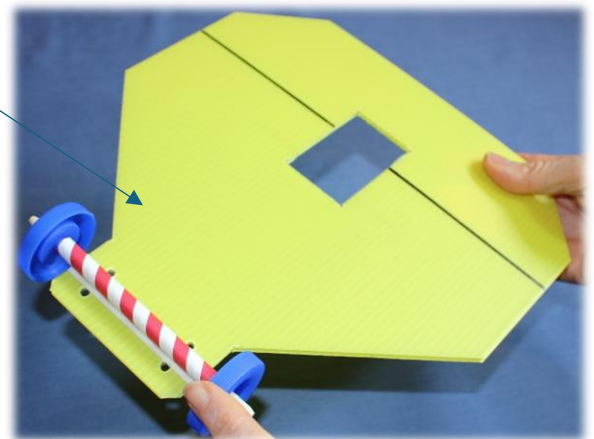

Step 7

Fit two cable ties through the holes and around the straw bearings as shown, but don't pull them too tight. The cable ties are to stop the bearing from moving around. However, pulling them too tight they may crush the straw bearing onto the axle and stop it rotating. Cut off the ends of the cable ties as short as possible with scissors. (The cable ties are thick so using large scissors and cutting near the hinge is recommended. Secateurs or wire cutters can also be used for this). Hold the base and spin the wheels again to check the axle still rotates freely in the bearing.



Step 8

Stick 10.5cm long strips of double-sided foam tape centrally along the two lines 7cm from the rear of the underside of the base. Use the sharp pencil to make holes on either side of the tape, roughly 1.3cm from the edge, supporting the base with Blu Tack as described in step 3. Enlarge the holes from either side until a cable tie fits through.

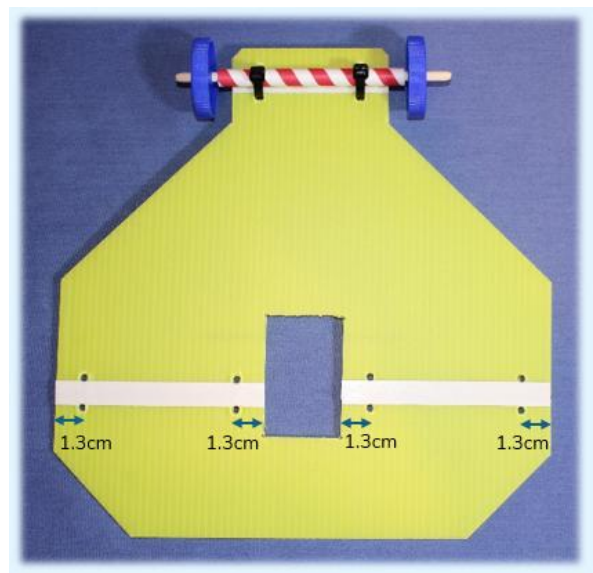

Step 9

Cut a 16cm long piece of wooden rod and sharpen the ends **very slightly**. This is to help you fit the pulley and wheel. (N.B. The length of the sharpened part must be less than 0.5 cm.) Mark the rod 0.5 cm from one end. Push on a pulley until you can just see the mark. The pulley should fit tightly.

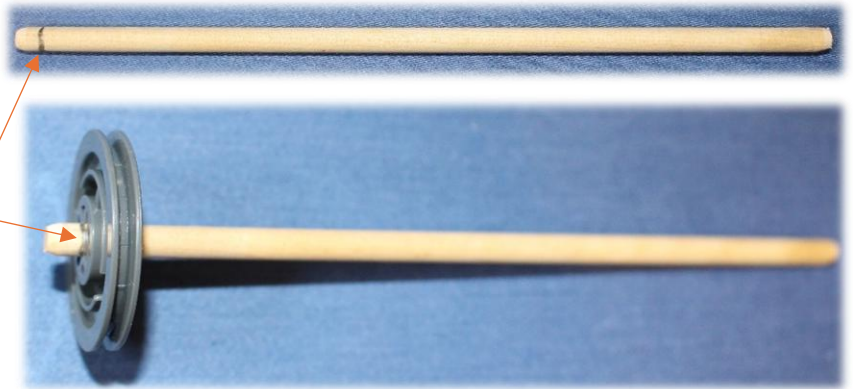

Step 10

Cut a piece of straw 12cm long and round out the cut end with a pencil. Make a mark 0.5cm from one end of the straw then slide the straw piece onto the rod, marked end first, up against the pulley.



Step 11

Fit a wheel onto the other end of the rod leaving a gap of about 2mm between the wheel and the end of the straw. If the rod is slightly too big or small in diameter refer to the note at the end of step 6.



Step 12

Remove the protective film and stick the straw to the foam tape, with the mark on the straw in line with the edge of the slot. Now the pulley should be in the slot and the straw should be overlapping the slot by 0.5cm. Hold the base and spin the wheel to check the axle turns easily in the bearing.

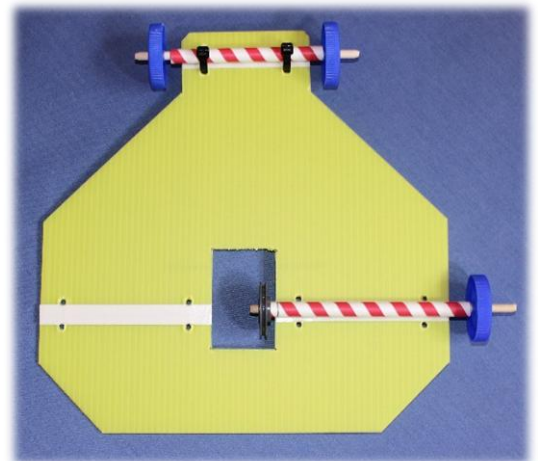

Step 13

Fit two cable ties as shown but don't pull them too tight. Cut off the ends of the cable ties as short as possible. Hold the base off the table and spin the wheel again to check the axle still rotates freely.

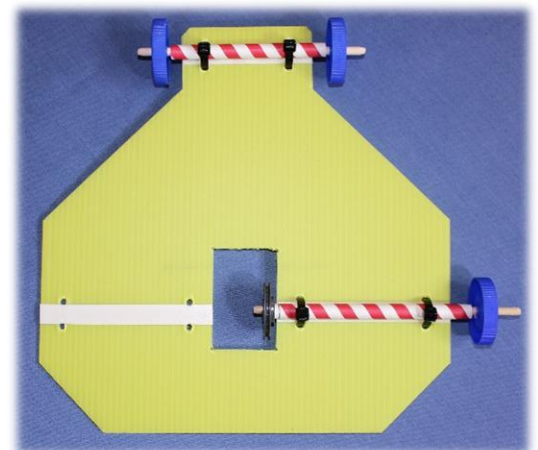

Step 14

Repeat steps 9 to 13 for the second pulley, wheel, rod and straw bearing. Make sure that there is a gap between the ends of the two rods. Turn the base over – you now have a rolling chassis.

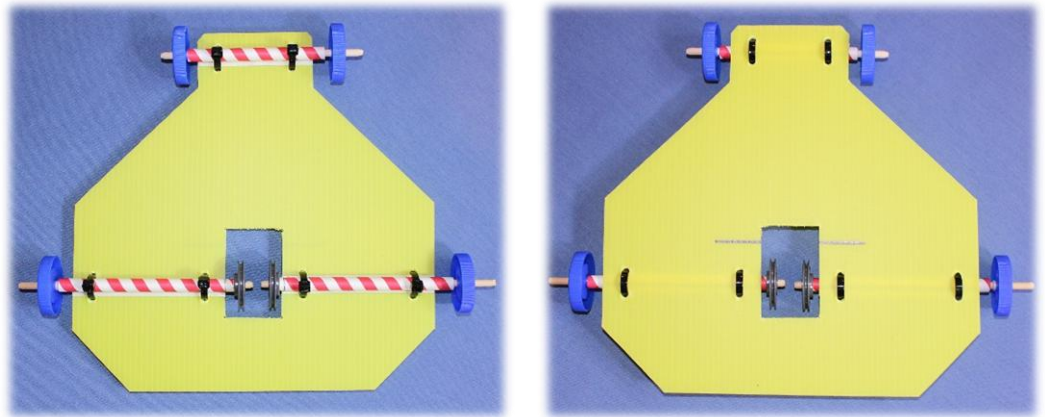

Step 15

Push the two motor pulleys onto the motor shafts as shown. Leave a gap of 1-2mm between the motor pulley and the motor housing.

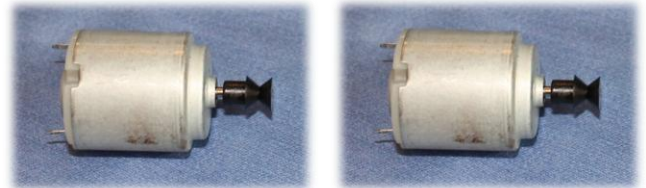

Step 16

Slide the two motors into the motor mounts in the direction shown by the orange arrow. If you push the motors in from above you can snap the motor mounts. Turn each motor until all the contacts are the same height.

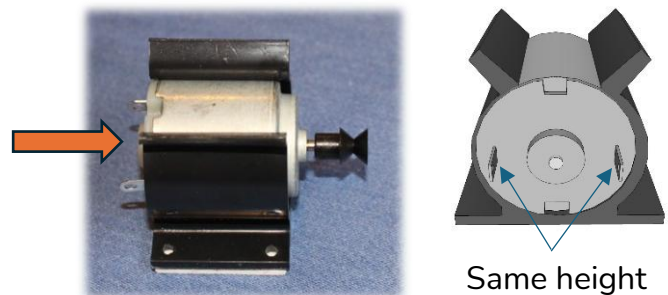

Step 17

Remove the plastic film from the bottom of a motor mount. Stick it to the top of the base so that the motor shaft is directly over the line you marked 10cm from the rear of the base. The vee of the motor pulley should line up with the vee of the pulley mounted on the axle. Repeat for the second motor mount.

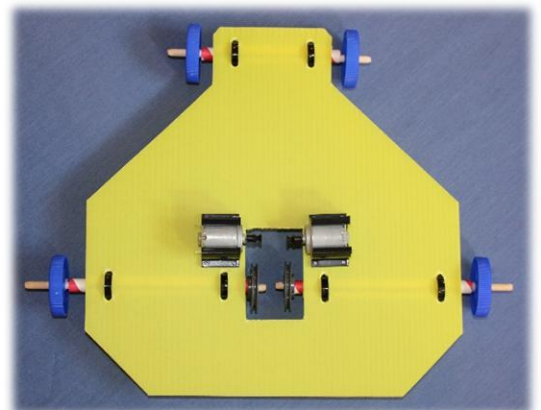
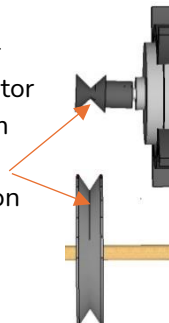

Step 18

Use the sharp pencil to make holes in the base on either side of the two motor mounts (supporting the base with Blu Tack as described in step 3). Be careful not to place the Blu Tack under the straw, as you can squash the straw. Fit two cable ties as shown. Pull the cable ties tight and snip off the ends with scissors. Fit the two rubber bands over the pairs of pulleys. You can slide the motors backwards and forwards in their mounts a little to line up the vees in the pulleys accurately.

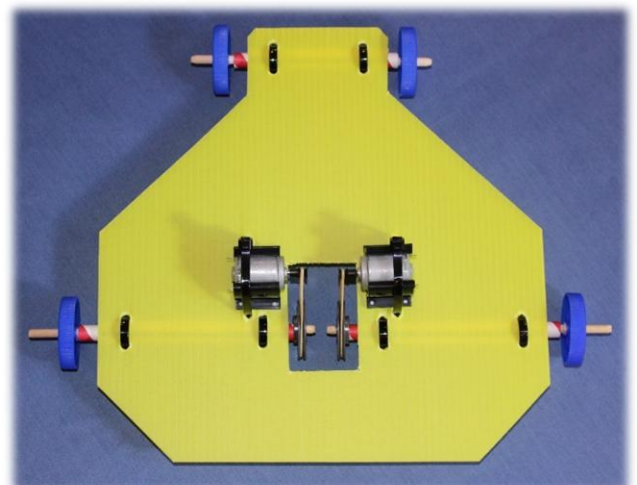

Step 19

Use one of the offcuts of corrugated plastic from the base to make the shape below left. Stick tape to the bottom of the battery box as shown. Attach the plastic shape to the battery box. Attach two more strips of foam tape as shown below left.

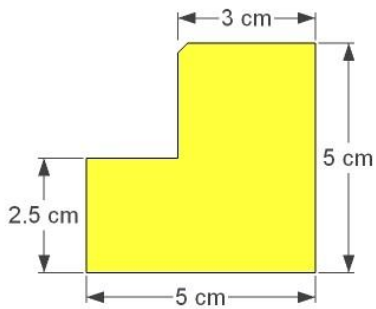

Make this shape

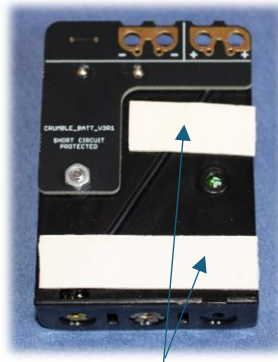

Stick tape to the bottom of the battery box

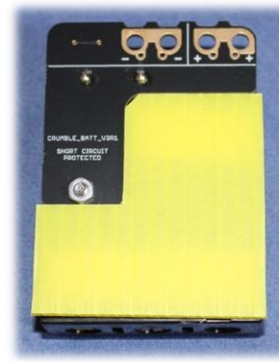

Attach the plastic shape

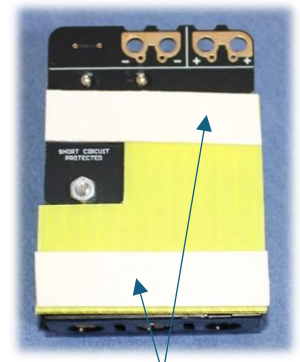

Stick on two more lengths of tape

Step 20

Stick a double layer of foam tape along the middle of the Crumble controller, on the side without the components. Remember to remove the protective film from the first layer before attaching the second layer. The double thickness is to allow space to attach the crocodile clips to the Crumble terminals.

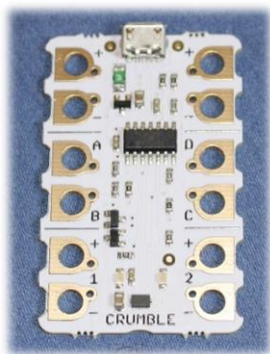

Don't stick tape this side

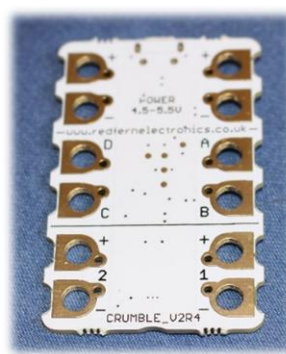

Stick tape this side

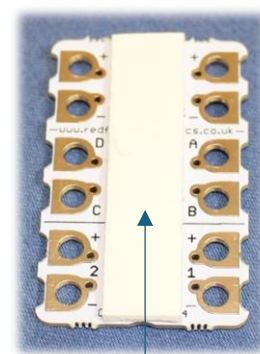

Attach a double layer of tape

Step 21

Peel off the protective film and attach the battery box and the Crumble to the base in the positions shown. Make sure the micro-USB connector is facing the front of the vehicle for ease of connection.

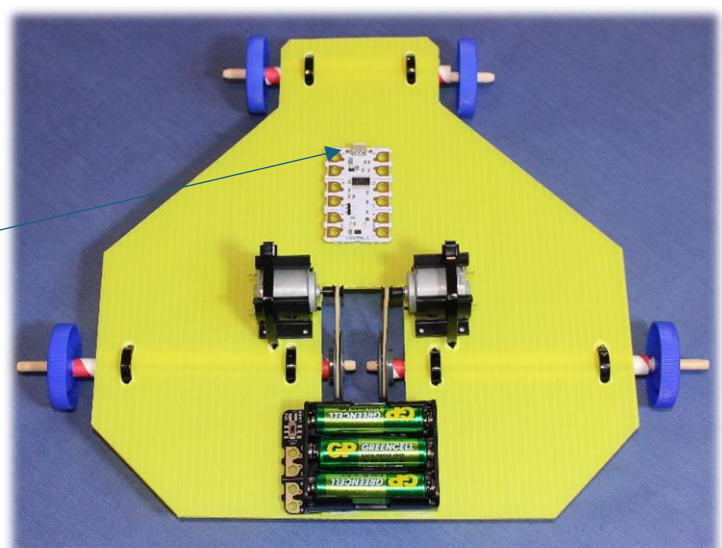

Step 22

Connect up the circuit shown on the right. Fit the cells into the battery holder (the right way round). Wrap the wires up neatly and cable tie them to the base. Position them so that the centre of gravity of the vehicle is just in front of the rear axles. This is because the driven wheels need to grip the floor, whilst the front wheels will need to skid when the vehicle turns. However, if the centre of gravity is too far back then the vehicle will tilt backwards as it accelerates across the floor. You can judge the position of the centre of gravity by balancing the vehicle on your fingertips, or by pressing down on the back of the vehicle and checking it is quite easy to tilt (but not too easy!).

Connect the Crumble controller to the computer using the micro-USB lead.

If you do not yet have the Crumble software installed on your computer then see the lesson plan for installation instructions.

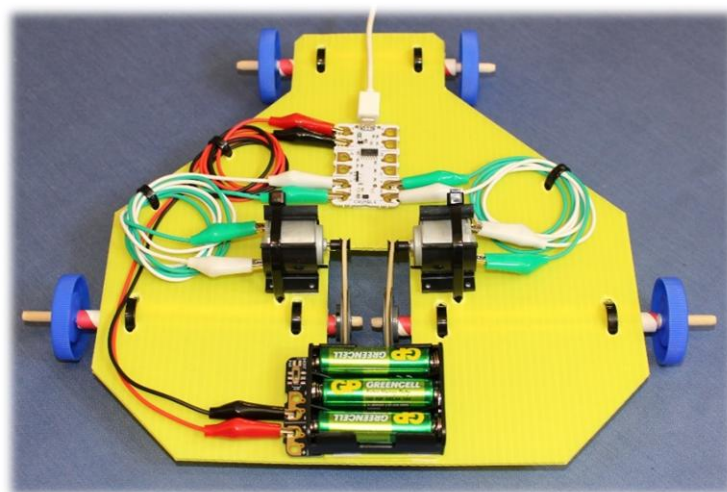
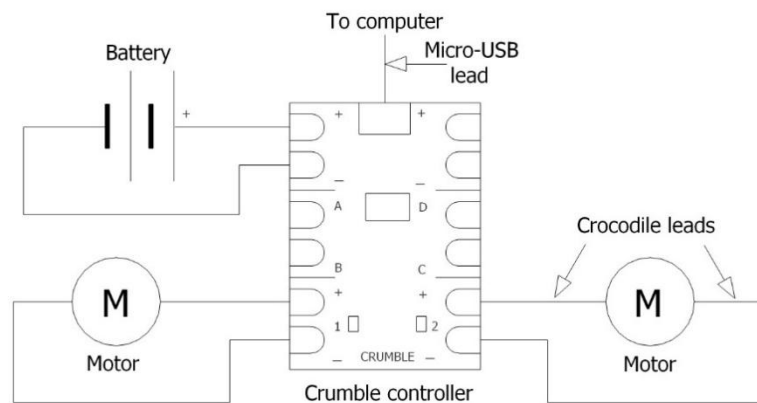

Step 23

Construct a program to run both motors at 50% of maximum power for 5 seconds:

First drag 'program start' from the list on the left and drop it into the blank space on the right.

Drag across 'motor 1 STOP' and attach to 'program start'. Click on 'STOP' and it will change to 'FORWARD at 75%'. Click on 75% and change to 50%.

Drag across another 'motor 1 STOP' command; click on the 1 to change it to motor 2, and change 'STOP' to 'FORWARD at 50%'.

Attach 'wait 1 seconds', then click on the '1' and type in '5'.

Attach 'motor 1 STOP' and 'motor 2 STOP' to finish.

The screenshot shows the Crumble software interface. The title bar reads "Crumble Version 1.0.0 - 2 motors.crm". The menu bar includes "File" and "Program". A notification says "New software available (1.0.13)". The interface has tabs for "Basic", "Input/Output", "Sparkles", "Control", "Variables", and "Operators". The main workspace contains the following code blocks:

- program start
- motor 1 FORWARD at 50 %
- motor 2 FORWARD at 50 %
- wait 5.0 seconds
- motor 1 STOP
- motor 2 STOP

Step 24

Hold the vehicle off the table, switch on the battery box then click on the green arrow (top left of the screen) to run your program. This will download the program to the Crumble controller itself. The two motors should run for 5 seconds and then stop. Save your program in the Crumble folder.

Step 25

Run the program again and check whether the wheels turn forwards. If either wheel turns backwards, swap over the crocodile clips attached to the relevant motor terminals, and the motor should turn the other way.

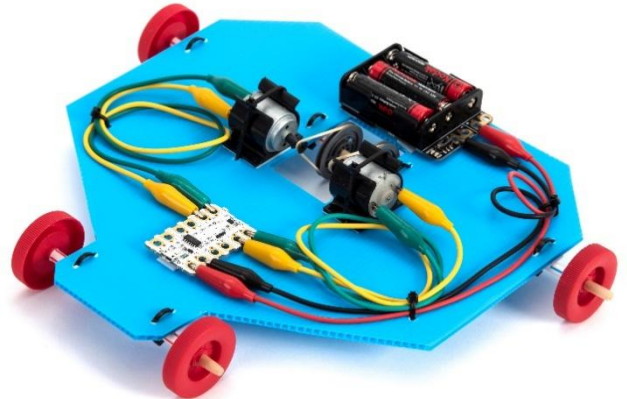

Step 26

Disconnect the micro-USB lead from the Crumble. Place the vehicle on a smooth floor. Switch the battery off and then switch on again. The vehicle should move forwards for 5 seconds and then stop. Switch the battery off when not in use to stop it draining. If you are short of space to run the vehicle, then reduce the wait to 3 seconds, for example.

Step 27

Program your vehicle to go forwards, backwards, then round in a circle (one motor forwards and the other backwards) – an example is shown here. Always start both motors on 50% power or less – otherwise they draw too much current and the Crumble cannot boot up. You can experiment with different motor speeds, following a course, three point turns and parallel parking.

Step 28

Don't forget to switch the battery off when not using your vehicle to stop the cells draining. Do not store your vehicle in sunlight (e.g. on the window sill), as this causes the rubber bands to perish. If the rubber bands lose stiffness and become loose then replace them.

